

**Features**

- Output Voltage: 3.3V, 5V, 12V and Adjustable Output Version
- Adjustable Version Output Voltage Range, 1.23V to 18V±4%
- 150KHz ±15% Fixed Switching Frequency
- Voltage Mode Non-Synchronous PWM Control
- Thermal-Shutdown and Current-Limit Protection
- ON/OFF Shutdown Control Input
- Operating Voltage can be up to 22V
- Output Load Current: 2A
- SOP-8L Packages
- Low Power Standby Mode
- Built-in Switching Transistor On Chip
- SOP-8L: Available in “Green” Molding Compound (No Br, Sb)
- Lead Free Finish/ RoHS Compliant (Note 1)

**General Description**

The AP1509 series are monolithic IC designed for a step-down DC/DC converter, and own the ability of driving a 2A load without additional transistor. It saves board space. The external shutdown function can be controlled by logic level and then come into standby mode. The internal compensation makes feedback control having good line and load regulation without external design. Regarding protected function, thermal shutdown is to prevent over temperature operating from damage, and current limit is against over current operating of the output switch. If current limit function occurs and  $V_{FB}$  is down below 0.5V, the switching frequency will be reduced. The AP1509 series operates at a switching frequency of 150KHz thus allow smaller sized filter components than what would be needed with lower frequency switching regulators. Other features include a guaranteed ±4% tolerance on output voltage under specified input voltage and output load conditions, and ±15% on the oscillator frequency. The output version included fixed 3.3V, 5V, 12V, and an adjustable type. The chips are available in a standard 8-lead SOP-8 package.

**Applications**

- Simple High-Efficiency Step-Down Regulator
- On-Card Switching Regulators
- Positive to Negative Converter

**Ordering Information**

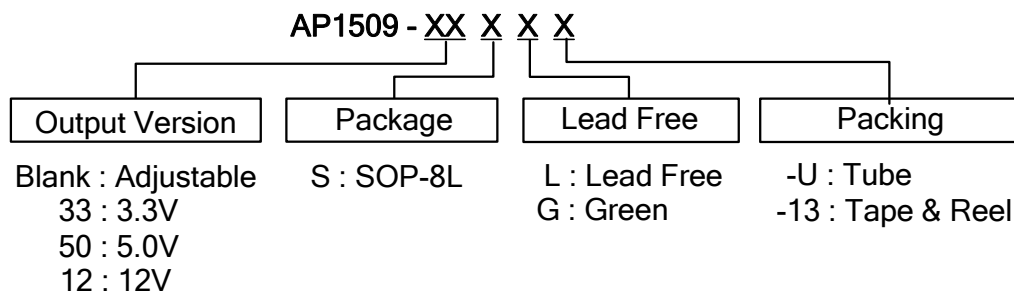

Device	Package Code	Packaging (Note 2)	Tube/Bulk		13" Tape and Reel	
			Quantity	Part Number Suffix	Quantity	Part Number Suffix
AP1509-XXS	S	SOP-8L	100	-U	2500/Tape & Reel	-13

Notes: 1. RoHS revision 13.2.2003. Glass and high temperature solder exemptions applied, see *EU Directive Annex Notes 5 and 7*.  
2. Pad layout as shown on Diodes Inc. suggested pad layout document AP02001, which can be found on our website at <http://www.diodes.com/datasheets/ap02001.pdf>.

**Pin Assignments**

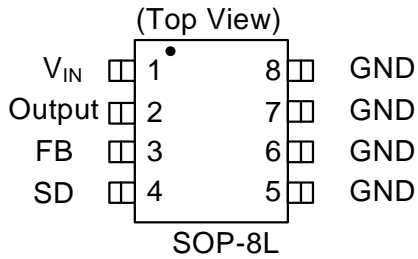

**Pin Descriptions**

Name	Description
V <sub>IN</sub>	Operating voltage input
Output	Switching output
GND	Ground
FB	Output voltage feedback control
SD	ON/OFF Shutdown

**Block Diagram**

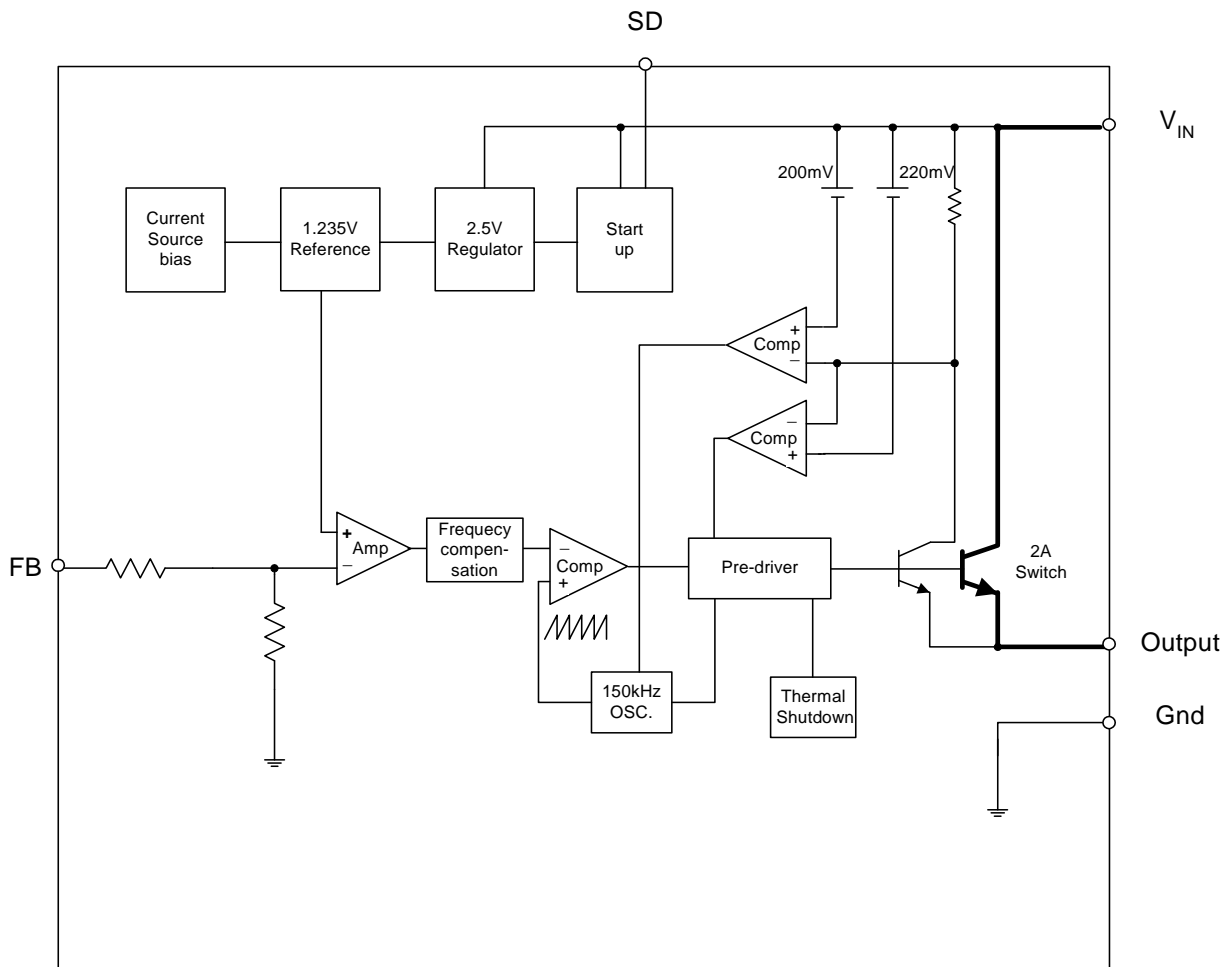

---

**Absolute Maximum Ratings**

---

Symbol	Parameter	Rating	Unit
ESD HBM	Human Body Model ESD Protection	2	KV
ESD MM	Machine Model ESD Protection	200	V
V <sub>CC</sub>	Supply Voltage	+24	V
V <sub>SD</sub>	ON/OFF Pin Input Voltage	-0.3 to +18	V
V <sub>FB</sub>	Feedback Pin Voltage	-0.3 to +18	V
V <sub>OUT</sub>	Output Voltage to Ground	-1	V
P <sub>D</sub>	Power Dissipation	Internally Limited	W
T <sub>ST</sub>	Storage Temperature	-65 to +150	°C
T <sub>J</sub>	Operating Junction Temperature	-40 to +125	°C

---

**Recommended Operating Conditions**

---

Symbol	Parameter	Min	Max	Unit
I <sub>OUT</sub>	Output Current	0	2	A
V <sub>OP</sub>	Operating Voltage	4.5	22	V
T <sub>A</sub>	Operating Ambient Temperature	-20	85	°C

### Electrical Characteristics (All Output Voltage Versions)

Unless otherwise specified,  $V_{IN} = 12V$  for 3.3V, 5V, adjustable version and  $V_{IN} = 18V$  for the 12V version.  $I_{LOAD} = 0.5A$

Specifications with **boldface type** are for full operating temperature range, the other type are for  $T_J = 25^\circ C$ .

Symbol	Parameter		Conditions	Min.	Typ.	Max.	Unit
$I_{FB}$	Feedback Bias Current		$V_{FB} = 1.3V$ (Adjustable version only)		-10	-50 <b>-100</b>	nA
$F_{OSC}$	Oscillator Frequency			127 <b>110</b>	150	173 <b>173</b>	KHz
$F_{SCP}$	Oscillator Frequency of Short Circuit Protect		When current limit occurred and $V_{FB} < 0.5V$ , $T_a = 25^\circ C$	10	30	50	KHz
$V_{SAT}$	Saturation Voltage		$I_{OUT} = 2A$ No outside circuit $V_{FB} = 0V$ force driver on		1.25	1.4 <b>1.5</b>	V
DC	Max. Duty Cycle (ON)		$V_{FB} = 0V$ force driver on		100		%
	Min. Duty Cycle (OFF)		$V_{FB} = 12V$ force driver off		0		
$I_{CL}$	Current Limit		Peak current No outside circuit $V_{FB} = 0V$ force driver on	3			A
$I_L$	Output = 0	Output Leakage	No outside circuit $V_{FB} = 12V$ force driver off			-200	$\mu A$
	Output = -1	Current	$V_{IN} = 22V$		-5		mA
$I_Q$	Quiescent Current		$V_{FB} = 12V$ force driver off		5	10	mA
$I_{STBY}$	Standby Quiescent Current		ON/OFF pin = 5V $V_{IN} = 22V$		70	150 <b>200</b>	$\mu A$
	$V_{IL}$	ON/OFF Pin Logic Input Threshold Voltage		Low (regulator ON)	-	0.6	V
$V_{IH}$	ON/OFF Pin Logic Input Threshold Voltage		High (regulator OFF)	2.0	-		
$I_H$	ON/OFF Pin Logic Input Current		$V_{LOGIC} = 2.5V$ (OFF)			-0.01	$\mu A$
$I_L$	ON/OFF Pin Input Current		$V_{LOGIC} = 0.5V$ (ON)		-0.1	-1	
$\theta_{JA}$	Thermal Resistance		SOP-8L	Junction to case	15		$^\circ C/W$
$\theta_{JC}$	Thermal Resistance with a copper area of approximately 3 in <sup>2</sup>		SOP-8L	Junction to ambient	70		$^\circ C/W$

**Electrical Characteristics (Continued)**

 Specifications with **boldface type** are for full operating temperature range, the other type are for  $T_J = 25^\circ\text{C}$ .

	Symbol	Parameter	Conditions	V <sub>Min</sub>	Typ.	V <sub>Max</sub>	Unit
AP1509-ADJ	V <sub>FB</sub>	Output Feedback	4.5V ≤ V <sub>IN</sub> ≤ 22V 0.2A ≤ I <sub>LOAD</sub> ≤ 2A V <sub>OUT</sub> programmed for 3V	1.193 <b>1.18</b>	1.23	1.267 <b>1.28</b>	V
	η	Efficiency	V <sub>IN</sub> = 12V, I <sub>LOAD</sub> = 2A	76	76		%
AP1509-3.3V	V <sub>OUT</sub>	Output Voltage	4.75V ≤ V <sub>IN</sub> ≤ 22V 0.2A ≤ I <sub>LOAD</sub> ≤ 2A	3.168 <b>3.135</b>	3.3	3.432 <b>3.465</b>	V
	η	Efficiency	V <sub>IN</sub> = 12V, I <sub>LOAD</sub> = 2A	78	78		%
AP1509-5V	V <sub>OUT</sub>	Output Voltage	7V ≤ V <sub>IN</sub> ≤ 22V 0.2A ≤ I <sub>LOAD</sub> ≤ 2A	4.8 <b>4.75</b>	5	5.2 <b>5.25</b>	V
	η	Efficiency	V <sub>IN</sub> = 12V, I <sub>LOAD</sub> = 2A	83	83		%
AP1509-12V	V <sub>OUT</sub>	Output Voltage	15V ≤ V <sub>IN</sub> ≤ 22V 0.2A ≤ I <sub>LOAD</sub> ≤ 2A	11.52 <b>11.4</b>	12	12.48 <b>12.6</b>	V
	η	Efficiency	V <sub>IN</sub> = 15V, I <sub>LOAD</sub> = 2A	90	90		%

**Typical Application Circuit**

**(1) Fixed Type Circuit**

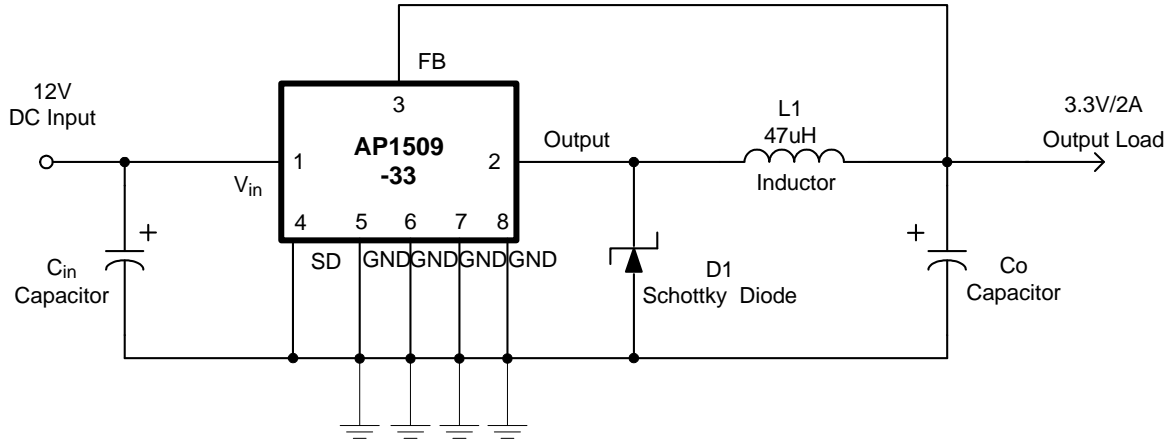

**(2) Adjustable Type Circuit**

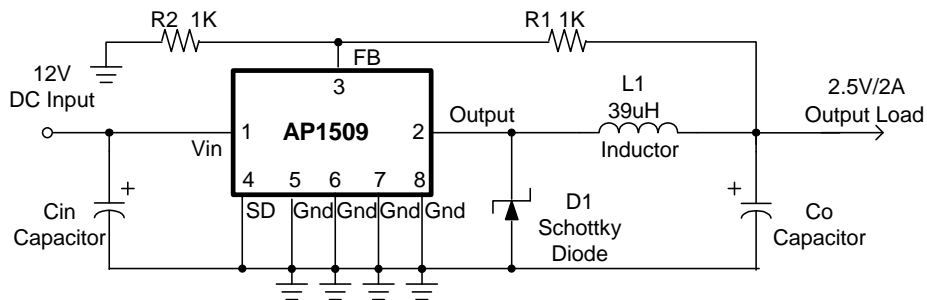

$$V_{out} = V_{FB} \times \left(1 + \frac{R1}{R2}\right)$$

$$V_{FB} = 1.23V$$

$$R2 = 1K \sim 3K$$

**(3) Delay Start Circuit**

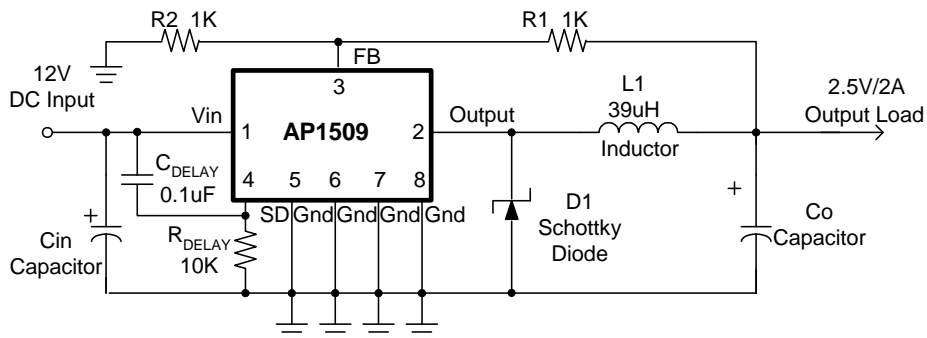

**Typical Performance Characteristics**

**AP1509 Efficiency vs. Temperature (Vin=12V, Vout=5V, Io=2A)**

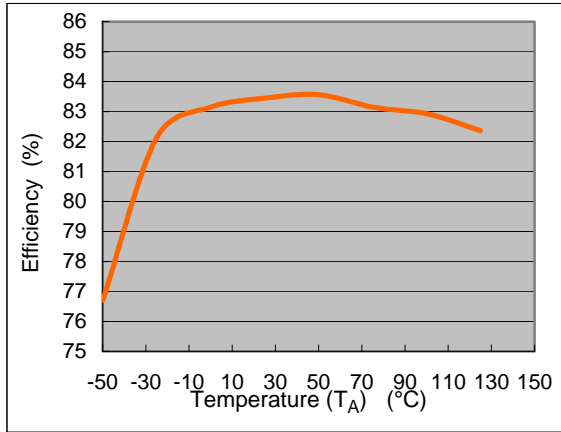

**AP1509 Efficiency vs. Temperature (Vin=12V, Vout=3.3V, Io=2A)**

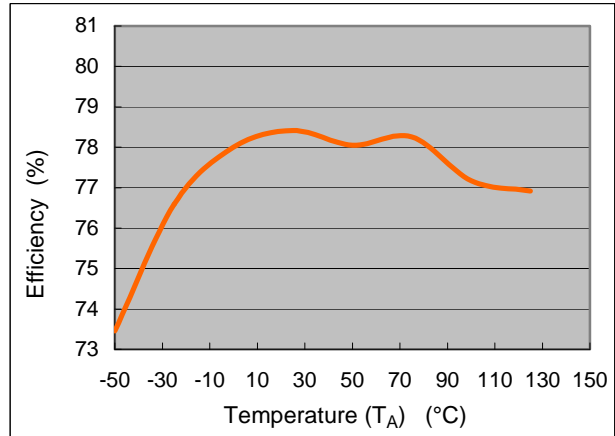

**AP1509 Saturation Voltage vs. Temperature (Vcc=12V, Vfb=0V, VSD=0)**

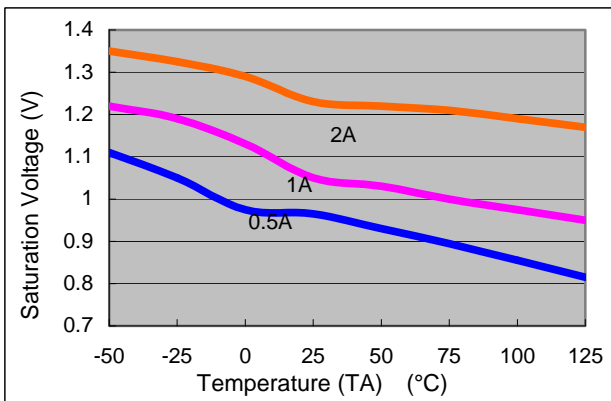

**AP1509 Switch Current Limit vs. Temperature (Vcc = 12V, Vfb = 0V)**

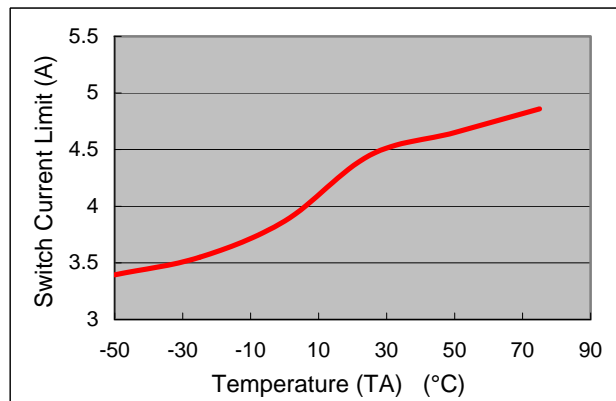

**AP1509 Supply Current vs. Temperature (Vcc=12V, No Load, Von/off =0V(Switch ON) , Von/off =5V(Switch OFF))**

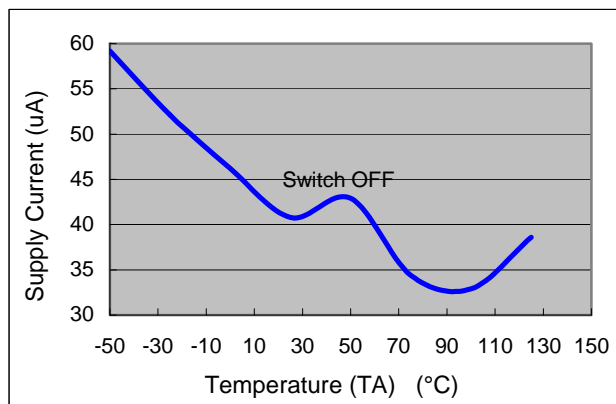
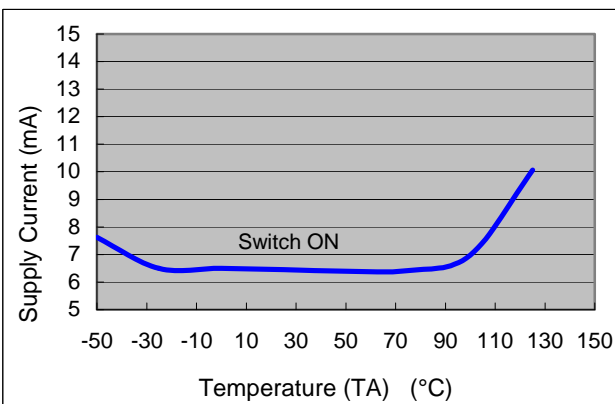

**Typical Performance Characteristics (Continued)**

**AP1509 Threshold Voltage vs. Temperature**  
(Vcc=12V, Io=100mA)

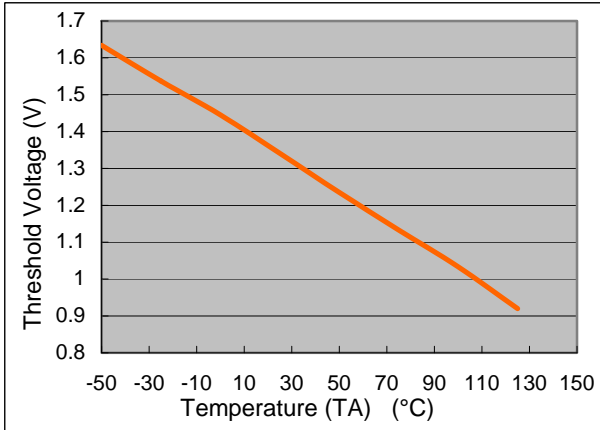

**AP1509 ON/OFF Current vs. ON/OFF Voltage**  
(Vin=12V)

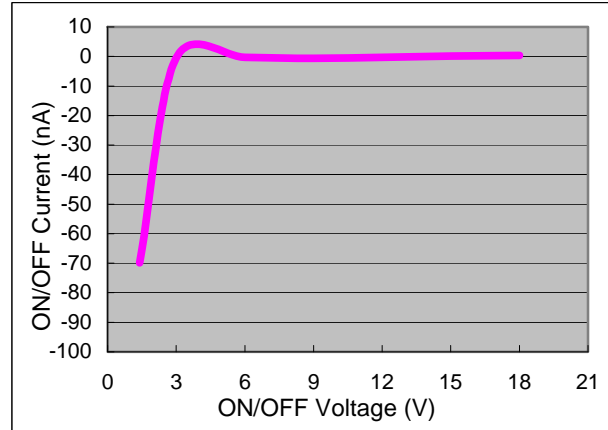

**AP1509 Frequency vs. Temperature**  
(Vcc=12V, Io=500mA, Vout=5V)

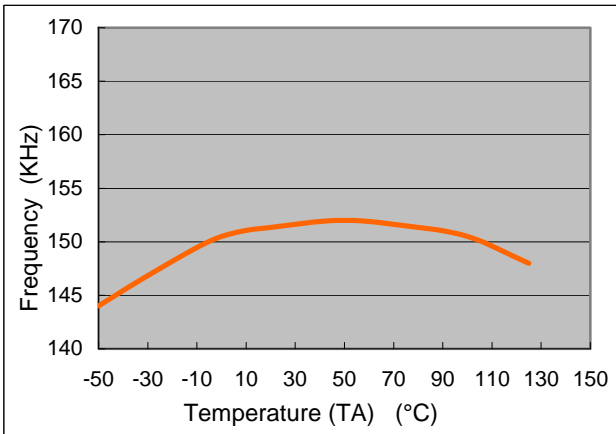

**AP1509 Feedback Current vs. Temperature**  
(Vcc=12V, Vout=5V, Vfb=1.3V)

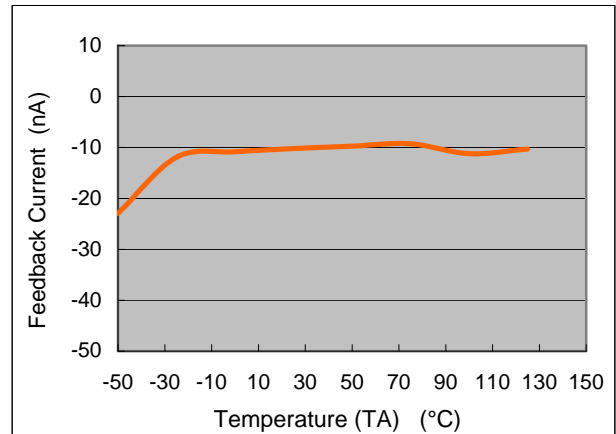

**AP1509 Output Voltage vs. Temperature**  
(Vin=12V, Io=2A)

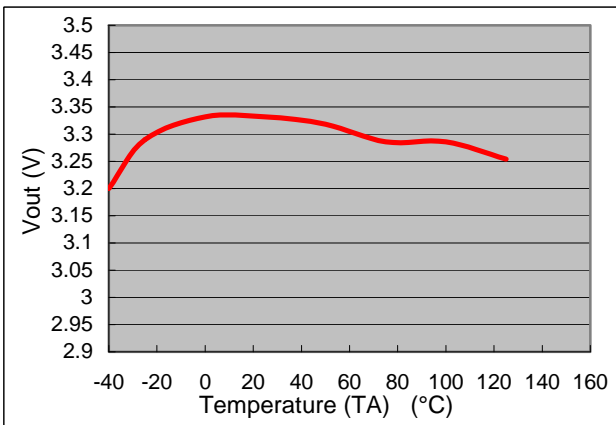



---

## Function Description

---

### Pin Functions

#### $+V_{IN}$

This is the positive input supply for the IC switching regulator. A suitable input bypass capacitor must be presented at this pin to minimize voltage transients and to supply the switching currents needed by the regulator.

#### Ground

Circuit ground.

#### Output

Internal switch. The voltage at this pin switches between  $(+V_{IN} - V_{SAT})$  and approximately  $-0.5V$ , with a duty cycle of approximately  $V_{OUT} / V_{IN}$ . To minimize coupling to sensitive circuitry, the PC board copper area connected to this pin should be minimized.

#### Feedback

Senses the regulated output voltage to complete the feedback loop.

#### SD

Allows the switching regulator circuit to be shutdown using logic level signals thus dropping the total input supply current to approximately 150uA. Pulling this pin below a threshold voltage of approximately 1.3V turns the regulator on, and pulling this pin above 1.3V (up to a maximum of 18V) shuts the regulator down. If this shutdown feature is not needed, the SD pin can be wired to the ground pin.

### Thermal Considerations

The SOP-8L package needs a heat sink under most conditions. The size of the heat sink depends on the input voltage, the output voltage, the load current and the ambient temperature. The AP1509 junction temperature rises above ambient temperature for a 2A load and different input and output voltages. The data for these curves was taken with the AP1509 (SOP-8 package) operating as a buck-switching regulator in an ambient temperature of 25°C (still air). These temperature increments are all approximate and are affected by many factors. Higher ambient temperatures require more heat sinker.

For the best thermal performance, wide copper traces and generous amounts of printed circuit board copper should be used in the board layout (One exception is the output (switch) pin, which should not have large areas of copper). Large areas of copper provide the best transfer of heat (lower thermal resistance) to the surrounding air, and moving air lowers the thermal resistance even further.

Package thermal resistance and junction temperature increments are all approximate. The increments are affected by a lot of factors. Some of these factors include board size, shape, thickness, position, location, and even board temperature. Other factors are, trace width, total printed circuit copper area, copper thickness, single or double-sided, multi-layer board and the amount of solder on the board.

The effectiveness of the PC board to dissipate heat also depends on the size, quantity and spacing of other components on the board, as well as whether the surrounding air is still or moving. Furthermore, some of these components such as the catch diode will add heat to the PC board and the heat can vary as the input voltage changes. For the inductor, depending on the physical size, type of core material and the DC resistance, it could either act as a heat sink taking heat away from the board, or it could add heat to the board.

**Typical Performance Characteristics**

**Feedback Voltage vs. Temperature**

$V_{in} = 5V; V_{out} = 15V$

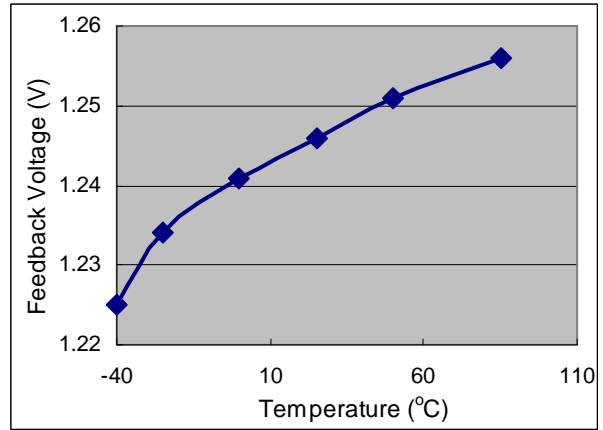
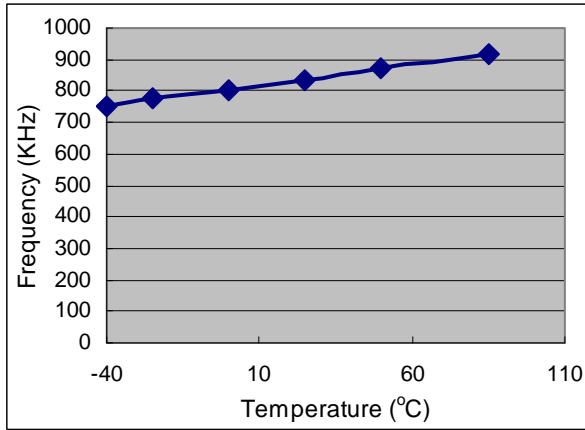

**Supply Current vs. Temperature**

$V_{in} = 5V; V_{out} = 15V; I_{out} = 0A$

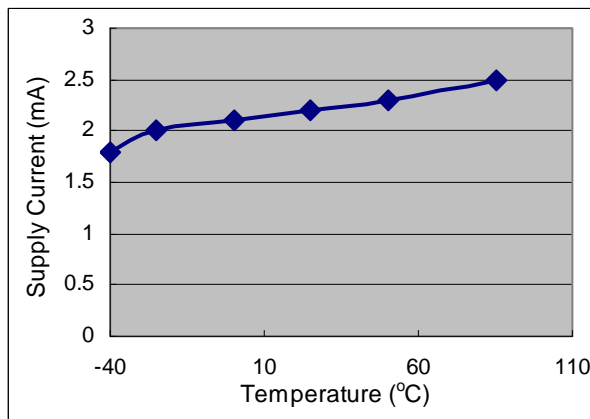

**Supply Current vs. Supply Voltage**

$V_{out} = 15V; I_{out} = 0A$

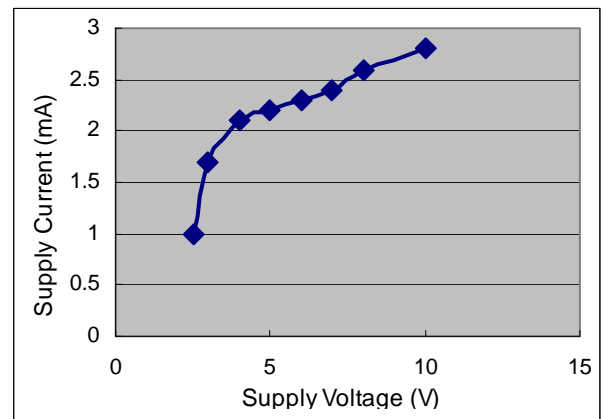

**Efficiency vs. Output Current**

$V_{in} = 5V; V_{out} = 15V$

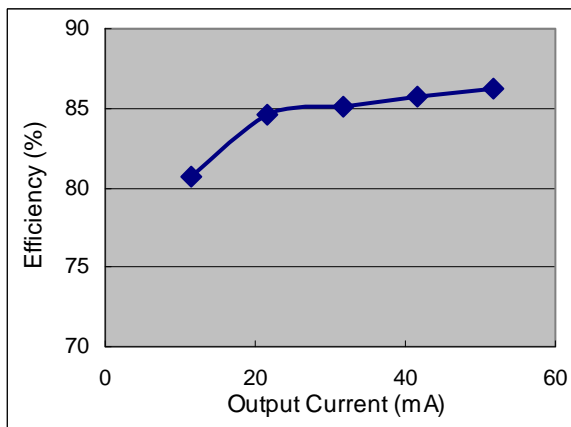

**Efficiency vs. Output Current**

$V_{in} = 3.3V; V_{out} = 15V$

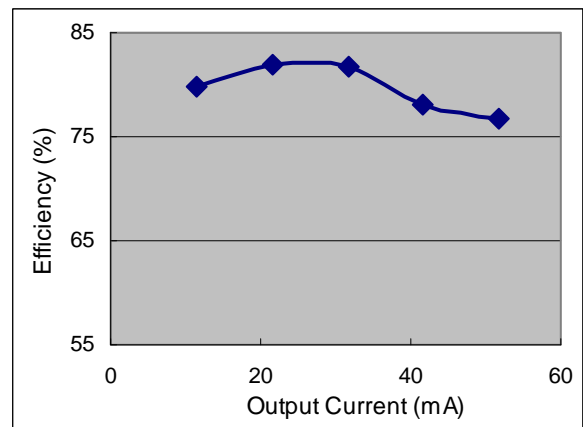

**Marking Information**

(1) SOP-8L

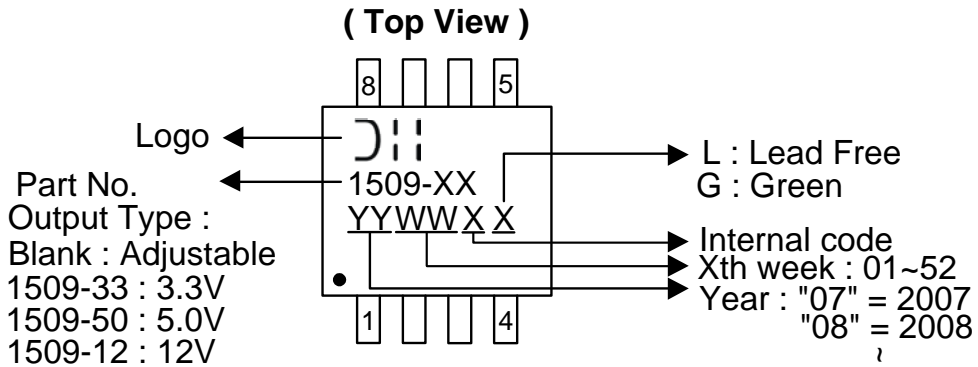

**Package Information (All Dimensions in mm)**

(1) Package Type: SOP-8L

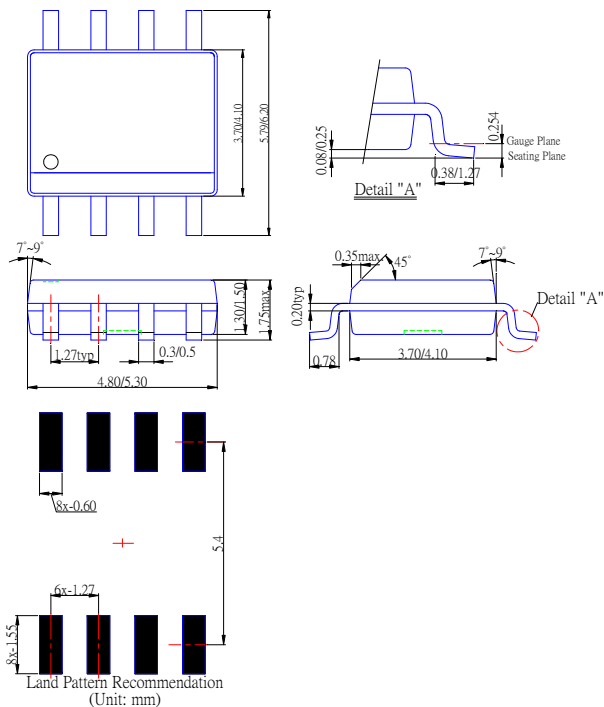

**IMPORTANT NOTICE**

Diodes Incorporated and its subsidiaries reserve the right to make modifications, enhancements, improvements, corrections or other changes without further notice to any product herein. Diodes Incorporated does not assume any liability arising out of the application or use of any product described herein; neither does it convey any license under its patent rights, nor the rights of others. The user of products in such applications shall assume all risks of such use and will agree to hold Diodes Incorporated and all the companies whose products are represented on our website, harmless against all damages.

**LIFE SUPPORT**

Diodes Incorporated products are not authorized for use as critical components in life support devices or systems without the expressed written approval of the President of Diodes Incorporated.